

Hydraulic Thruster Break

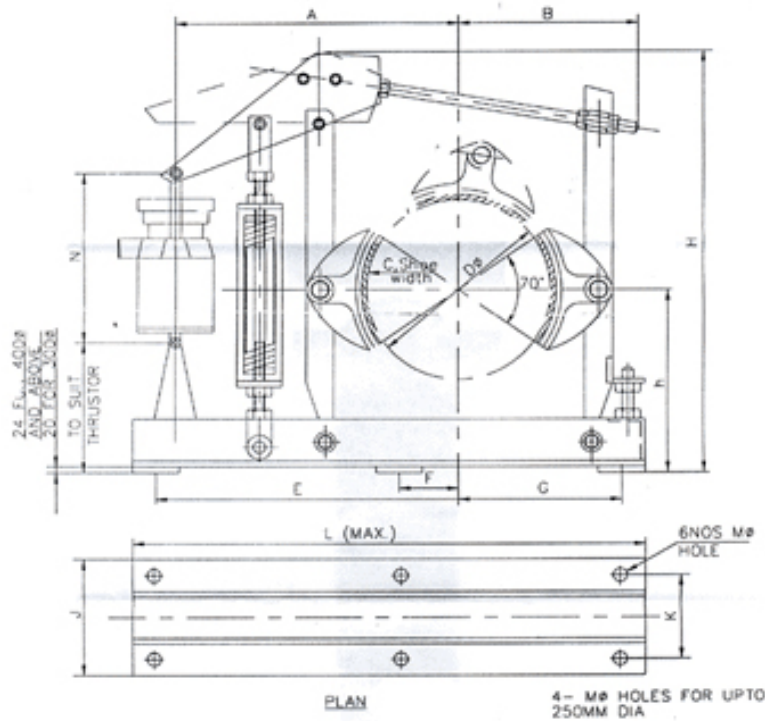

Model No.	Drum Dia	Braking Torque (KG.M)	Thruster Details			Length (max)	Width (max)	Height (max)
			Model No.	Force (KG)	Stroke (MM)			
HTB-EHTB-100/18	100	6	HTB-EHT-18	18	51	425	140	430
HTB-EHTB-150/18	150	9	HTB-EHT-18	18	51	550	200	450
HTB-EHTB-160/18	160	10	HTB-EHT-18	18	51	550	200	450
HTB-EHTB-200/18	200	20	HTB-EHT-18	18	51	675	200	450
HTB-EHTB-200/34	200	32	HTB-EHT-34	34	51	763	225	575
HTB-EHTB-250/18	250	35	HTB-EHT-18	18	51	725	200	525
HTB-EHTB-250/34	250	42	HTB-EHT-34	34	51	850	225	575
HTB-EHTB-300/18	300	42	HTB-EHT-18	18	51	850	225	575
HTB-EHTB-300/34	300	62	HTB-EHT-34	34	51	850	225	625
HTB-EHTB-400/46	400	90	HTB-EHT-34	34	51	1000	238	675
HTB-EHTB-400/68	400	110	HTB-EHT-46	46	51	1000	238	675
HTB-EHTB-500/46	500	190	HTB-EHT-46	46	51	1525	262	700
HTB-EHTB-500/68	500	290	HTB-EHT-68	68	76	1525	262	700
HTB-EHTB-600/68	600	350	HTB-EHT-68	68	76	1625	262	775